

THIS DRAWING AND SPECIFICATIONS ARE THE PROPERTY OF THE PERFORMANCE WINDOW GROUP. THEY ARE ISSUED IN STRICT CONFIDENCE AND SHALL NOT BE REPRODUCED, COPIED OR USED AS THE BASIS FOR MANUFACTURING WITHOUT WRITTEN PERMISSION.

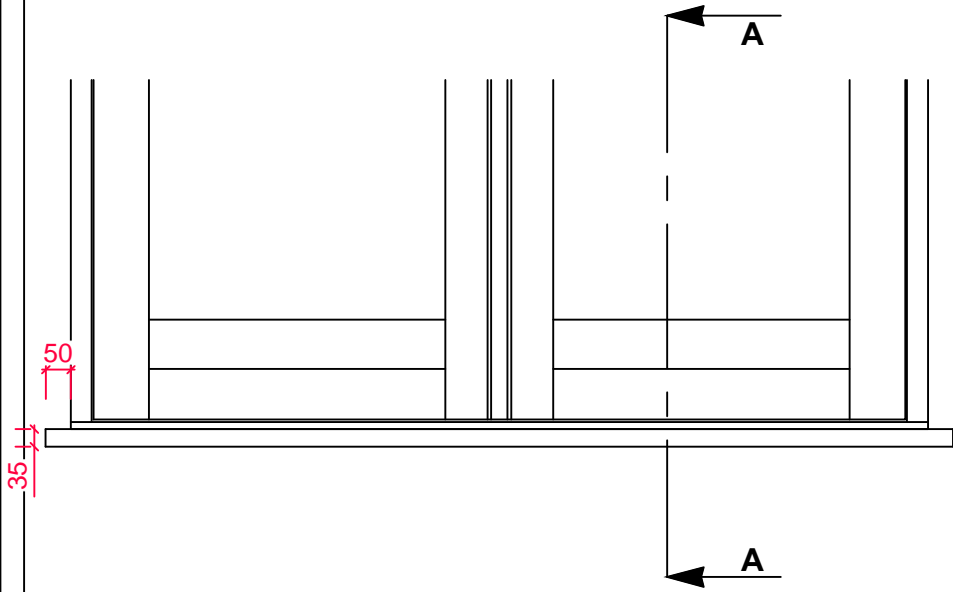

**35mm CILL ELEVATION WITH
50mm HORNS L+R**

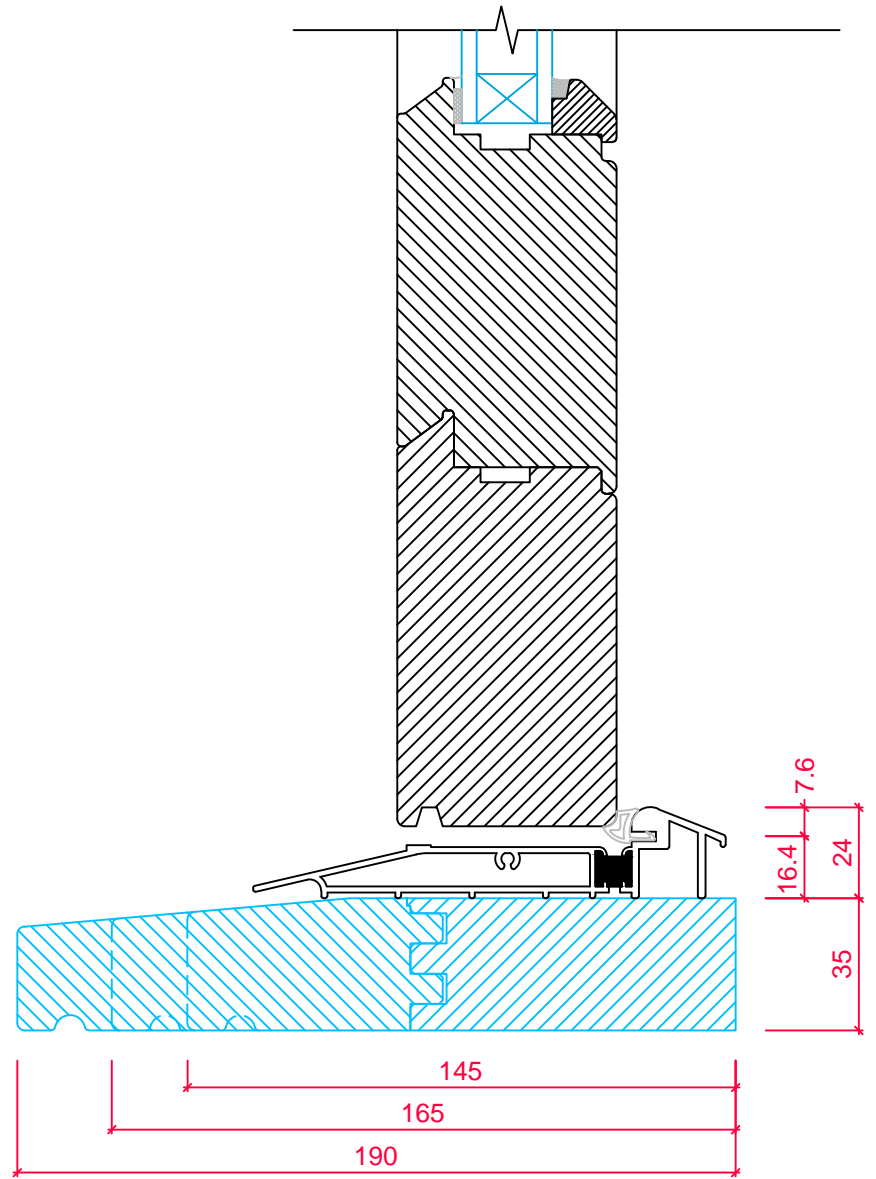

35mm CILL OPTIONS SECTION 'A-A'

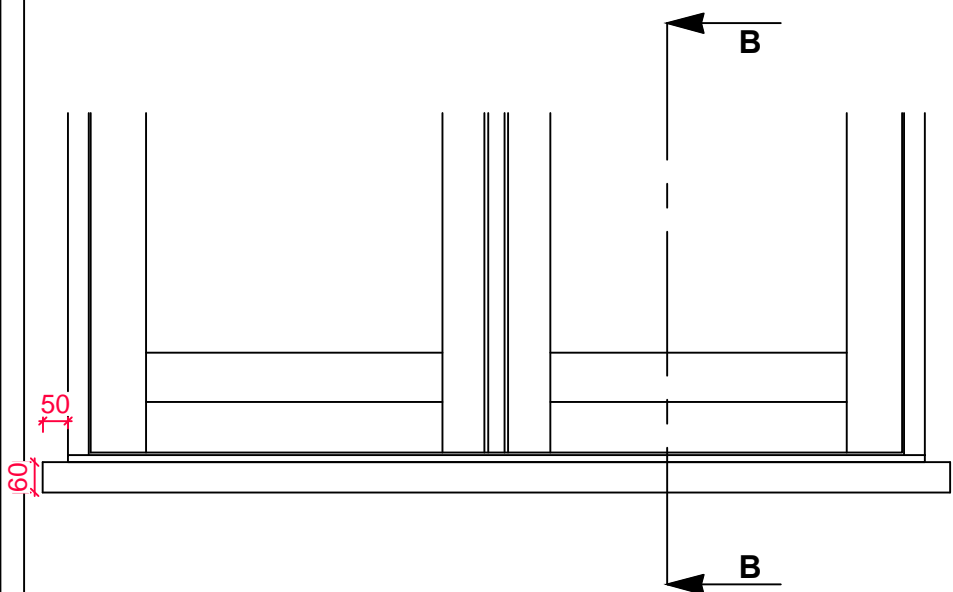

**60mm CILL ELEVATION WITH
50mm HORNS L+R**

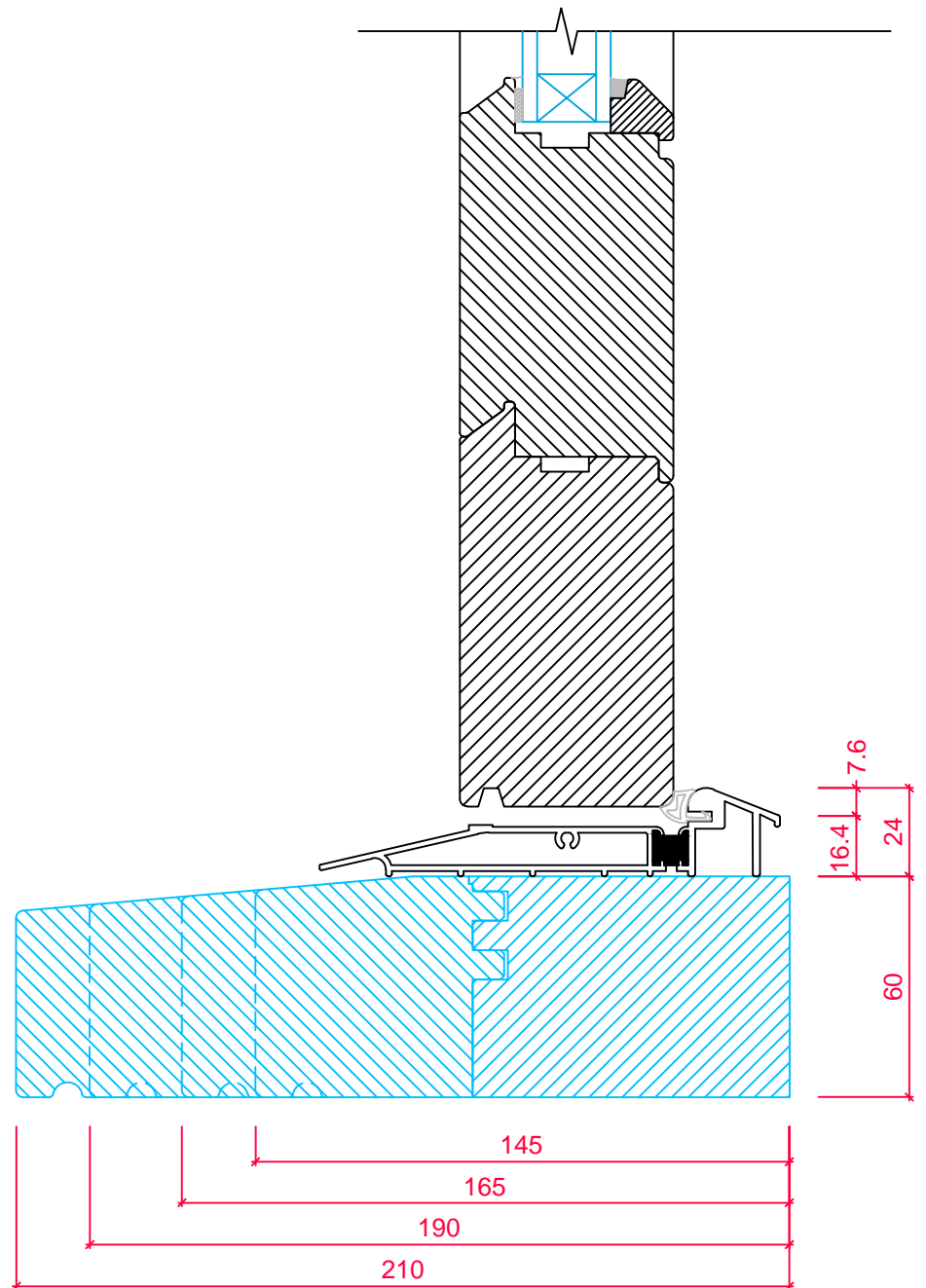

60mm CILL OPTIONS SECTION 'B-B'



TOLERANCES
UNLESS OTHERWISE SPECIFIED

ALL DIMENSIONS IN MM
ALL LINEAR DIMENSIONS ± 0.4
ALL ANGLE DIMENSIONS $\pm 0.5^\circ$
BREAK ALL SHARP EDGES 0.5

PRODUCT RANGE:
FRENCH DOOR (Open Out)

TITLE
VERTICAL SECTION DETAIL
- PROJECTING CILL OPTIONS

Rev B

DRAWN BY: LH DATE DRAWN: 01/03/2017 SCALE: 1:2, 1:15